

Product description



Item	Metal Rfid Access Control Keypad for Door Access Control System
Model	ACM105
Verification Method	RFID Card /Password/RFID Card +Password
Door Open Time	0-99 seconds
Storage RFID capacity	1,000 Users,Support management card,Easy management
Material	Metal shell, aluminium alloy
Proximity Range	3-15CM
Frequency	13.56MHz
Wiegand Signal	Wiegand 26/34 output,Support use as a wiegand card reader
Access Control Interface	Electric lock, Door sensor, Exit button, alarm, DoorBell
Quickly Authorization	Support data backup and copy,The same user,quickly authorization the same series machine users quickly
Easy to Management User	Support management card easy to add user card and delete user card
Optional Functions	Mf Cards/Waterproof IP65
Voltage	DC 12V
Color	Black, Silver and Gold
Operating Temperature	0°C - 45°C
Operating Humidity	20%-80%
Dimensions	117mm×78mm×22mm(L*W*D)
Gross Weight	0.5kg

Benefit

1. Metal case,Narrow frame design,touch screen access control reader.
2. Completely independent access control, can be directly implemented user passwords, cards and many other features management support card, password via touch keyboard input.
3. Large storage RFID capacity: 1000
4. Support easy management card
5. Wiegand output, Support use as a wiegand card reader and Surge absorption protection.
6. Protection level is IP65.

Product display



78
mm

117
mm



Size: 117x78x22mm

Touch Screen Standalone Access Controller

city us films what to be handed films what the what to offer the films access a collection city us films what to be handed
e what to offer the films access a collection city us films what to be handed



U disk transfer data



Voice function



IC card



Full touch button



1000 User





OLED LCD screen



Import ARM32-bit CPU system



Backlit doorbell button



U disk transfer information.



Aluminum body



Tamper alarm function

[Detailed image](#)

Supports Wiegand 26/34 output, can be used as access control to the card reader door

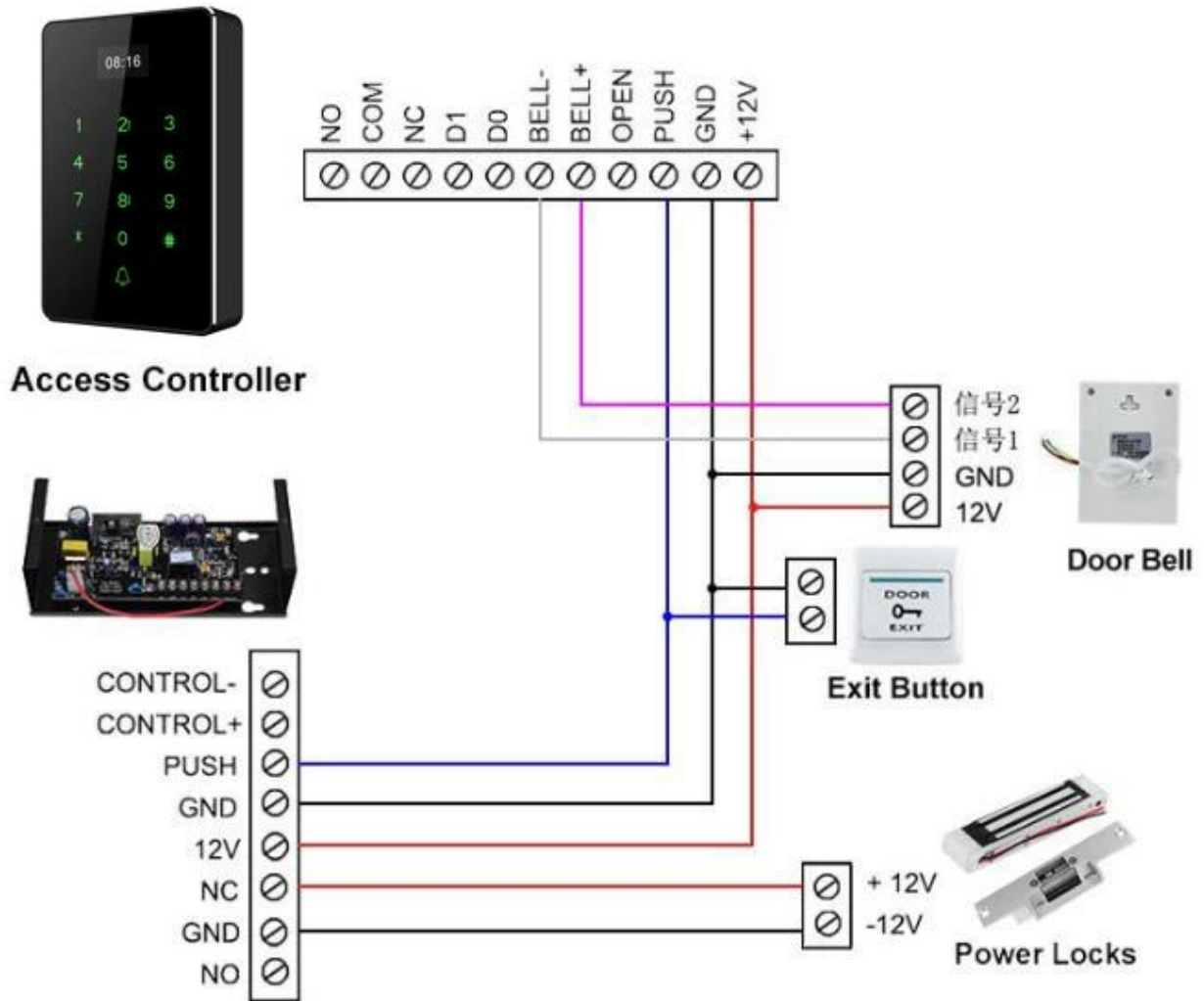

Our service

Our service

1. Any request will be answered within 24 hours
2. Professional manufacturer and supplier, welcome to visit our website and factory
3. OEM / ODM available
4. High quality, fashin desing, reasonable and competitive price, quick delivery time
5. after sales service:
 - A: All products will have been strictly checked in-house before packing
 - B: All the products will be well packed before shipping
 - C: All our products have a 2-3 year warranty if the damage is not caused by the human being
6. Faster delivery: about 1 ~ 5 days for sample order, 7 ~ 30 days for bulk order
7. Payment: you can pay for the order through: T / T, Western Union, Paypal, Ali commercial insurance
8. Shipping: we have a strong cooperation with DHL, FEDEX, TNT, UPS, EMS, forwarder by sea and by air, you can also choose your own forwarder.

Quality assurance

- The warranty service will be honored if the damage is not caused by the human being, ACM Goldbridge provides a 2 year warranty for the related products.

- On the contrary, ACM Goldbridge will further increase in case of repair.
- Further information, consult our service center.

Packaging and delivery



Shipping way

We work closely with DHL, FEDEX, TNT, UPS, EMS, forwarder of SEA and AIR
You can also choose your forwarder.

package

Keypad access control packaging: 1 unit per box, 100 pieces per carton,
Carton size: 45 * 31 * 28cm, Gross weight: 13kg.

Our company

ACM Shenzhen Goldbridge industrial company

As one of the leading exporters of RFID products in China, we have been present in this field for 20 years. We have rich experience in manufacturing and exporting RFID products. Our strength products are: RFID card, RFID remote control, RFID bracelet, RFID tag and various RFID readers. We are also the provider of access control solutions.



Contact

For any questions or requests please do not hesitate to let us know. We are confident that any information on your part will receive our prompt attention and response. You can contact us through Alibaba online or offline. Our offline contact information is as follows.



SHENZHEN GOLDBRIDGE INDUSTRIAL CO., LTD

Address: Futian District, Shenzhen of China

Telephone: +86-755-83767678

Contact Person: Lily Jiang

WhatsApp and Mobile Phone: +86-13554918707

Skype: lily-jiang1206

E-mail: sales@goldbridgesz.com

Website: <http://www.goldbridgesz.com>